

CONTENTS

- I. Why Align Rotating Equipment?
- II. Defining Shaft Misalignment
- III. Alignment Methods — Poor, Fair, Good and Best
- IV. Pre-Alignment Considerations
- V. Alignment Methods
 - A. Rim and Face Alignment
 - B. Reverse Dial Indicator/Laser Alignment
 - C. Across the Flex Element Alignment

I. Why Align Rotating Equipment?

When two pieces of rotating equipment are connected through a shaft coupling, every effort should be made to minimize coupling and shaft misalignment. Proper alignment will reduce bearing, shaft and coupling failures, bearing and coupling temperature, vibration, and energy consumption. In addition, good alignment will extend equipment life between planned maintenance intervals. When considering how precise the alignment needs to be, consider alignment limitations of all the system components, not just the coupling. A flexible coupling is no excuse for excessive misalignment.

II. Defining Shaft Misalignment

For two shafts to be called “aligned,” their shaft centerlines need to coincide. If together these centerlines do not form one line, then either parallel misalignment (Fig. 1) And/or angular misalignment Exists (Fig. 2).

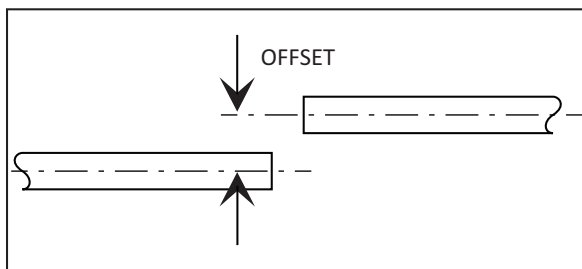

Fig. 1 Parallel misalignment

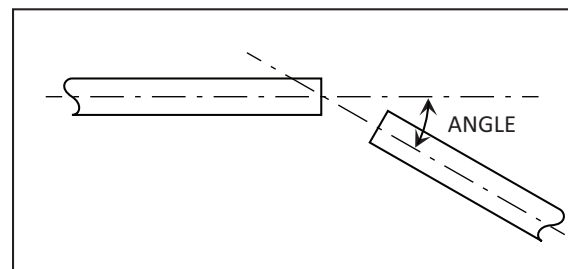

Fig. 2 Angular misalignment

In addition, as misalignment can exist in many directions, it is conventional to describe both of these misalignments in two planes, the vertical and the horizontal to define the complete alignment condition present.

Another type of alignment that is often overlooked is the axial misalignment. The coupled shafts axial position can change as a result of many factors such as thermal growth, connected equipment thrust forces, pump volute gap adjustments and sleeve bearing motor end float. In addition to this, some couplings may generate thrust forces as a result of applied torque, speed and misalignment. Be sure the proper type of coupling for the application is used and that you are within its published axial operating limits.

III. Alignment Methods – Poor, Fair, Good and Best

Below is a table showing the relative ranking of different alignment methods. In this publication, we will cover the recommended methods 3, 4 and 5.

Method		Rating	Comment
1	Straight edge and caliper	Poor	A straight edge is used to check the parallel misalignment and a caliper is used to check the angular misalignment. Coupling and equipment life may be sacrificed using this method. <i>Not recommended.</i>
2	Straight edge with feeler gauges and inside micrometer	Fair	Same as above method with improved accuracy. <i>Not recommended.</i>
3	Rim and face	Good	Dial indicator mounted on one shaft hub reading off of the other determines parallel misalignment by measuring on hub outer rim and angular misalignment by measuring on hub flange face. In situations where only one piece of equipment can be rotated this is an acceptable option. <i>Recommended</i>
4	Reverse Dial Indicator or Laser Alignment	Best	Dial indicator is mounted on one hub/ shaft and measures on Rim of other hub/ shaft. Dial indicator is then reversed to other shaft and steps are repeated. Graphically, these measurements give you the extension of one shaft centerline with respect to the other shaft centerline and give you the alignment corrections graphically needed to bring the equipment shafts into alignment. Both shafts must be rotated together. <i>Recommended</i>
5	Across the Flex element	Good	Used for applications where an indicator bracket or laser may not be practical due to large span or obstructions. <i>Recommended</i>

IV. Pre-Alignment Considerations

Before doing the equipment alignment, there are several items that must be considered.

SOFT FOOT

Soft foot occurs when a piece of equipment, such as a motor, is not sitting flat on its base or it rocks. The rocking can be eliminated by tightening down the hold down bolts; however, this puts the motor bearings under undue strain and may cause an increase in vibration. A soft foot condition may also result in erroneous alignment readings.

Checking and correcting Soft Foot:

With all of the hold down bolts tightened, place a dial indicator on one of the foot pads as close to a bolt head as possible, loosen the bolt and read the deflection as shown in Fig. 3 - a measured deflection greater than .002" should be shimmed. After shimming, tighten the bolt and move onto the next foot pad and repeat the procedure. Alternatively, many laser alignment systems have a soft foot mode that can be used.

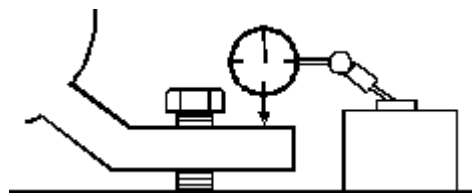

Fig. 3
Soft Foot Check

THERMAL GROWTH

Always consider if your equipment will move in any direction from the "cold" condition to the "hot" running condition when it reaches operating speed and temperature. If the growth is significant, you must *deliberately* misalign your equipment in the cold condition so that alignment is achieved when it is operating and up to temperature. As you can see from the below example the amount of vertical growth can be significant:

Thermal growth example:

A steam turbine with an operating casing temperature of 450° F is coupled to a pump that operates at an ambient temperature of 80° F. The distance from base to the shaft centerlines is 20". If both pieces of equipment are aligned cold (80° F), at operating temperature the turbine will rise with respect to the pump .048" $[(.0000065\text{in}/\text{in}^\circ \text{F}) \times (20 \text{ in}) \times (450^\circ \text{F} - 80^\circ \text{F})]$.

To properly align this equipment vertically, in the cold condition you would shim the pump shaft .048" high with respect to the turbine shaft.

INDICATOR SAG

If using a dial indicator for alignment, you need to determine the difference in the dial indicator reading when it is at the 12:00 o'clock position on top compared to when it is on the 6:00 o'clock position on the bottom. The difference in these readings is a result of gravity deflecting the indicator bracket away from the shaft it is reading in the bottom position. It is not necessary to eliminate sag but rather to know what it is and adjust for it in your final alignment readings.

Determining Indicator Sag:

Indicator sag is determined by rigidly mounting the indicator bracket on a rigid piece of pipe with the dial indicator stem resting on top in the 12:00 o'clock position as seen in Fig. 4. In this position, set the indicator at "0" (zero) and roll the pipe until the indicator is at the bottom 6:00 o'clock position on the pipe. In the example shown in Fig. 5, the indicator sag was measured at *negative* -.005 inch.

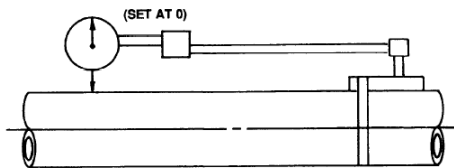

Fig. 4

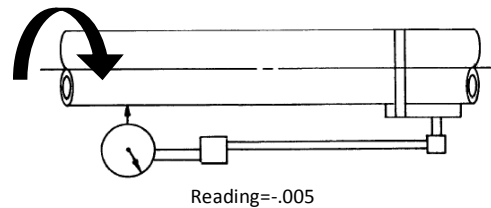

Fig. 5

Comments Regarding Indicator Sag:

1. The indicator sag reading will always be a negative number.
2. It is used only to correct the vertical top to bottom readings (for the horizontal or side-to-side readings it is ignored as they cancel).
3. The indicator bracket should be as light and as rigid as possible. It is general practice to try and limit the amount of indicator sag to not greater than 10% of your largest indicator reading.

V. Alignment Methods

To explain the 3 recommended alignment methods from Section III, we will use a motor connected to a pump as our example. Regardless of the method used you must correct the alignment in the vertical and the horizontal plane.

- First, correct the vertical misalignment by shimming under the equipment feet.
- Second, correct the horizontal misalignment by moving the equipment side to side.

A. Rim and Face Alignment

Step 1: Refer to section IV for Pre-Alignment considerations

Step 2: Determine which piece of equipment is “fixed” and which piece of equipment is “moveable”. In general, you will only be moving one piece of equipment and it is typically, but not limited to, the drive motor.

Step 3: Equipment layout

On a piece of graph paper, lay out the piece of equipment being aligned as seen in Fig. 6. The distances that you will need to measure and plot are:

1. Distance from where the indicator rides radially on the pump hub, to the center of the motor front feet. In this example, this is 15”.
2. Diameter of the pump hub flange, at the location the face indicator rides. In the example this is 10” (shown in the graph plot).
3. Distance from the center of the motor front feet to the center of the motor back feet. In this example this is 25”.

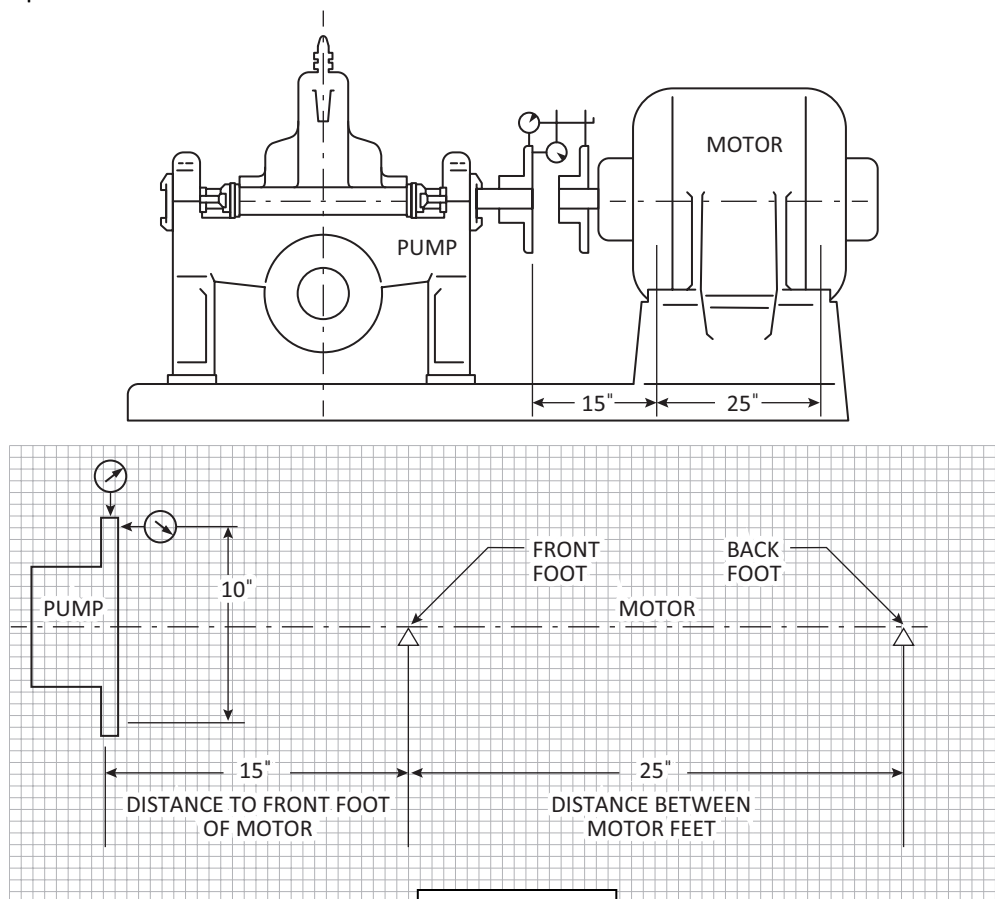
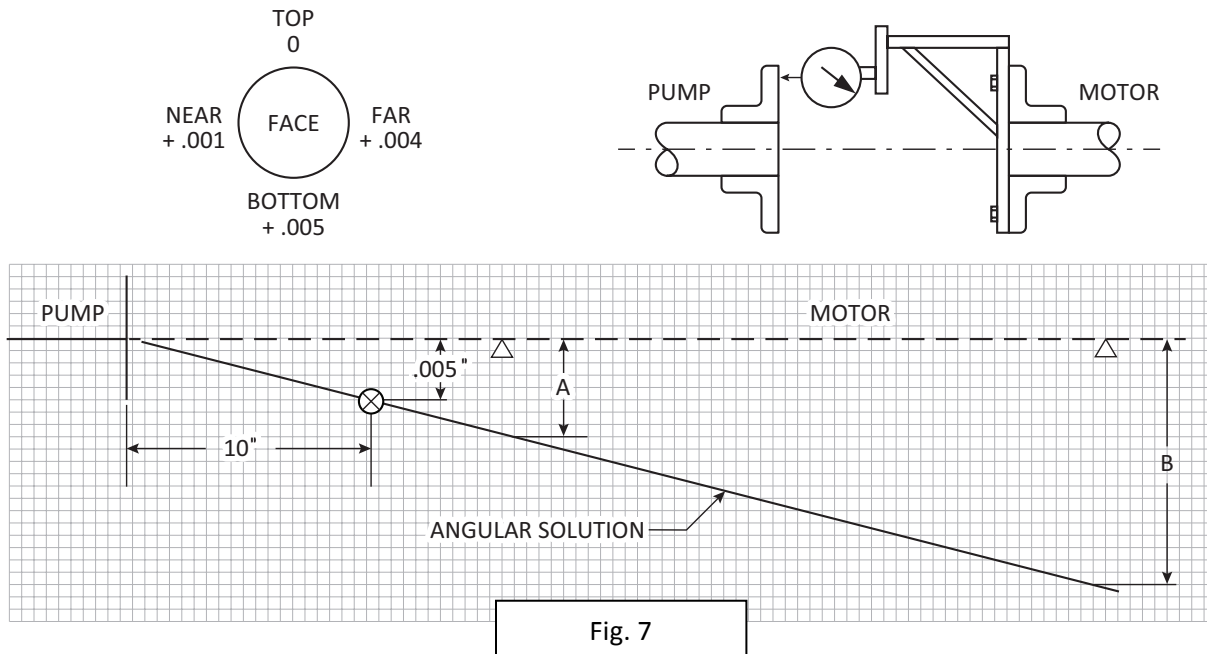

Fig. 6

The horizontal scale on the graph used here is one small division equals one inch.

Step 4: Mount bracket and sweep readings (Vertical solution)

With the indicator bracket attached to the motor and the indicator reading off the pump hub face, rotate the shaft in 90° increments and take readings as shown in Fig. 7. Make sure that both shafts being aligned are axially restrained, as any endplay will distort the face readings!



Step 5: Interpret Face reading (Vertical Solution):

Reading on the face at a 10-inch diameter you measure +.005 at the bottom, which means the indicator stem was compressed .005 inches for every 10 inches of length. This can only happen when the motor shaft centerline extension is low with respect to the pump shaft centerline extension.

Step 6: Plot face reading (Vertical solution)

Extend the 10-inch face-measuring diameter along the dashed pump centerline. Using a vertical scale of one small square equals .001 inch, plot the .005 inches below the pump centerline. As seen in Fig. 7, the line drawn between the pump flange center and through the plotted point, extended past the plane of the motor feet. This line represents the *angular only* orientation of the motor shaft centerline with respect to the pump shaft centerline.

Step 7: Shim to Correct Angular Misalignment (Vertical solution)

At the location on figure 7 of the front motor feet (A) and the back motor feet (B) count the number of squares below the shaft centerline to the motor shaft centerline extension. To bring the motor shaft into angular alignment in the vertical plane you would shim the front motor feet .0075 inch and shim the back feet .0020 inch.

Step 8: Move indicator from face to rim position

With the motor bracket still attached to the motor hub, set the indicator stem on the outside rim of the pump hub.

Step 9: Sweep rim readings

Zero the dial indicator on top, rotate it in 90-degree increments and take readings as shown in Fig. 8.

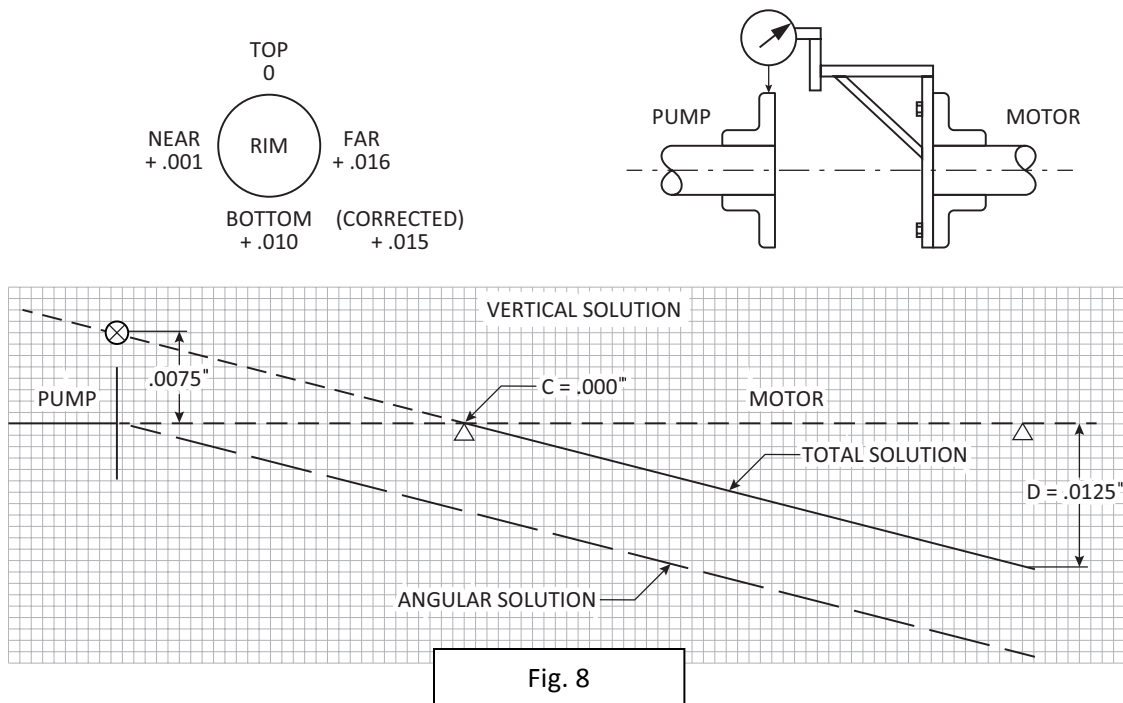

Fig. 8

Step 10: Correct bottom rim reading (Vertical solution)

The bottom dial indicator reading measured +.010 inches, but this reading must be corrected for the indicator sag discussed in section IV. To correct the reading you subtract the indicator sag reading (-.005) from the bottom dial indicator reading (+.010) to give you an actual reading of +.015 $[(.010 - (-.005)) = +.015]$.

Step 11: Plot rim reading (Vertical solution)

As this is a T.I.R. (Total Indicator Reading) it is two times the actual shaft to shaft relation. $+.015 \div 2 = +.0075$. .0075 is where the motor shaft centerline extension is relative to the pump shaft centerline at the pump hub. With the pump established as the fixed piece of equipment, a corrected plus reading at the bottom means the dial indicator stem was compressed which can only occur if the motor shaft centerline is high with respect to the pump shaft centerline. Using a scale of one small division on the graph equal to .001 inches, plot this point as shown in Fig. 8. The parallel offset or rim misalignment alone could be corrected by removing .0075 inches of shims from under both the front and back motor feet.

ALTERNATIVE

By drawing a line parallel to the angular (face) solution and thru the parallel offset point the total solution can be read off the graph at "C" and "D". In this example C=0 and D=.0125 inch. The complete vertical alignment solution (angular and parallel) is to add .00125-inch shims to the back motor feet. In this way, you shim the equipment only once for the full vertical solution. Vertically the equipment is now aligned; let's move to the horizontal solution.

Step 12: Angular or Face Solution (Horizontal):

For the horizontal (side-to-side) results, the same procedure is used. Zero one of the side readings by subtracting this reading from the "near" and "far" measurements. Indicator sag can be ignored as it cancels out. Plot these readings and the results can be read off of the graph as shown in Fig. 9.

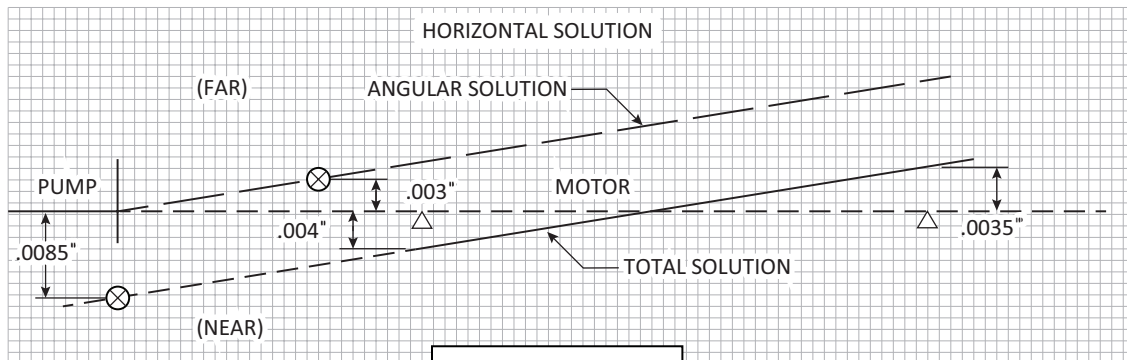

Fig. 9

B. Reverse Dial Indication/ Laser Alignment

In principle, Reverse Dial Indication (RDI) and Laser Alignment are identical alignment methods each capable of similar accuracy. Below we will cover Reverse Dial Indication method in detail as it explains all the concepts of these two methods in a more understandable graphical sense. If you understand RDI alignment, Laser Alignment method is easy to understand.

Reverse Dial Indication Alignment

Step 1: Refer to section IV for Pre-Alignment considerations

Step 2: Determine which piece of equipment is “fixed” and which piece of equipment is “moveable”. In general, you will only be moving one piece of equipment and it is typically, but not limited to, the drive motor.

Step 3: Equipment layout

On a piece of graph paper, lay out the piece of equipment being aligned as shown in Fig. 10. The distances needed are:

1. Distance from where the first indicator rides on the pump hub to where the second indicator rides on the motor hub. In the example shown below, this is 10-1/2 inches.
2. Distance from where the second indicator rides on the motor hub to the center of the front motor feet. In the example shown below, this is 2-1/2 inches.
3. Distance from the center of the motor front feet to the center of the motor back feet. In the example shown below, this is 5-1/4 inches.

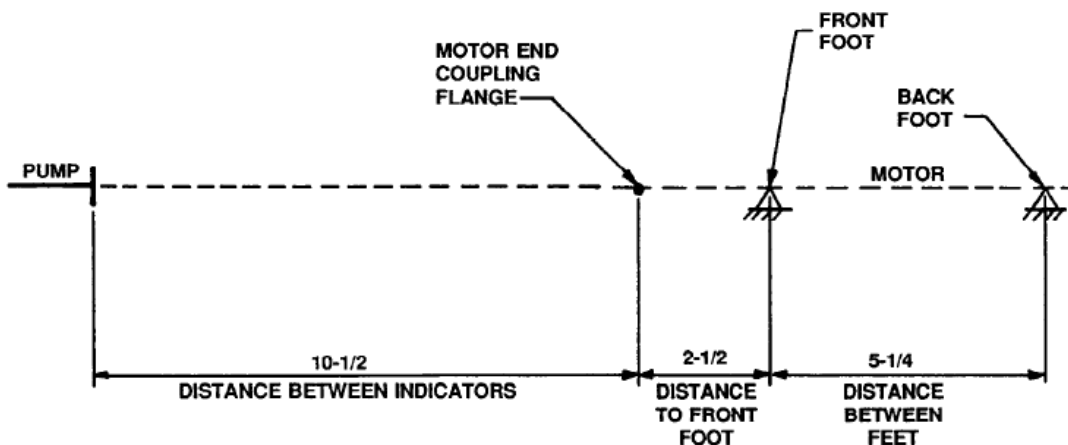

Fig. 10

Step 4: Sweep pump hub readings

With the indicator bracket attached to the motor hub reading off the rim of the pump hub, zero the indicator on the top and rotate shafts together in 90° increments and take readings.

Step 5: Correct bottom pump hub reading (Vertical solution)

The bottom reading must be corrected for indicator sag, which from section IV we determined this to be negative $-.005$ inch. To correct the bottom reading you subtract the indicator sag from the bottom indicator reading. The bottom indicator reading was $-.025$ $- (-.005)$ give us the corrected reading of $-.020$ as shown in Fig. 11.

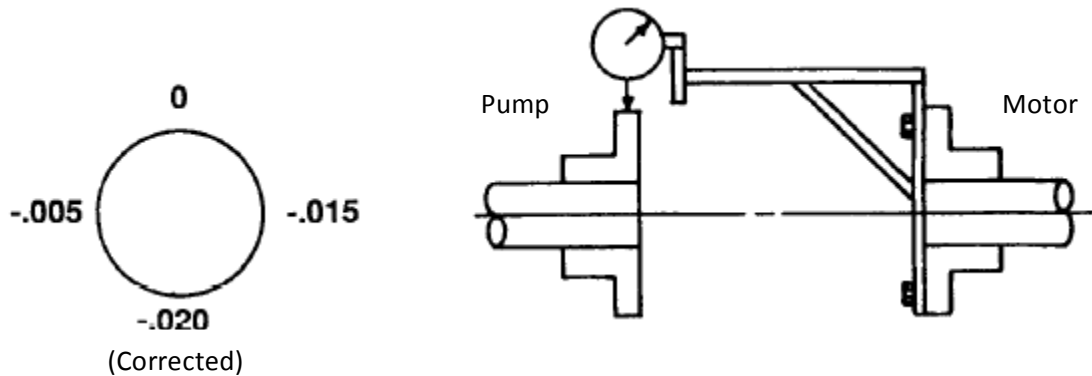

Fig. 11
From Motor to Pump

Step 6: Plot the first point (vertical solution)

The $-.020$ value is a TIR (Total Indicator Reading) and is two times the actual shaft to shaft distance ($-.020 \div 2 = -.010$). Negative $-.010$ is the distance between the motor shaft extension centerline and the pump shaft centerline in the plane of the pump hub. A negative sign indicates the dial indicator stem extended at the bottom. With the pump being fixed, the only way this can occur is if the motor shaft is low with respect to the pump shaft. On your graph paper using a scale of small division equal to $.001$, plot this point as shown in Fig. 12.

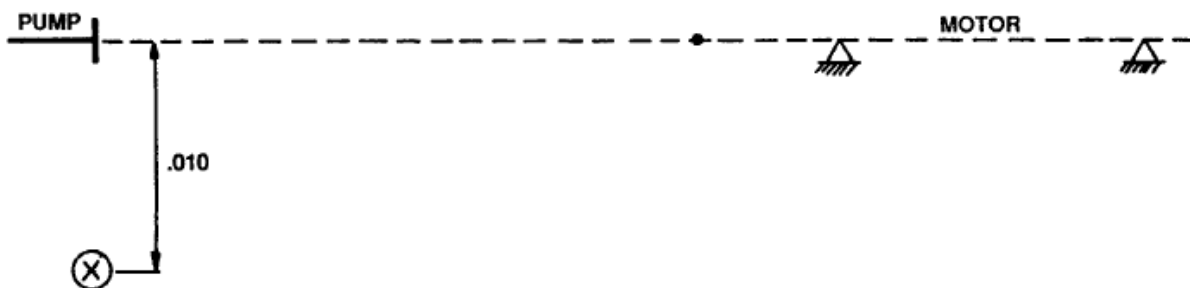

Fig. 12

Step 7: Reverse the indicator to read the motor hub and sweep readings

Now reverse the indicator setup so the bracket is attached to the pump hub and is reading off the rim of the motor hub. As before, zero the indicator on the top and rotate shafts together in 90° increments and take readings.

Step 8: Correct bottom pump hub reading (Vertical solution)

The bottom reading must again be corrected for indicator sag. Subtract the negative $-.005$ indicator sag from the bottom indicator reading of $+.005$ gives you a corrected bottom reading of $+.010$. [$+.005 - (-.005) = +.010$] as shown in Fig. 13.

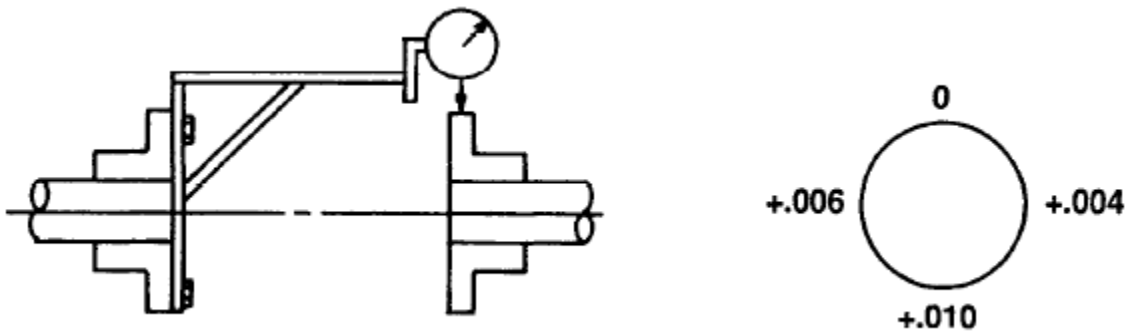

Fig. 13
From Pump to Motor

Step 9: Plot the second point (vertical solution)

The $+.010$ value is a TIR number that we divide by 2 to give us $+.005$, which is the distance between the motor shaft extension centerline and the pump shaft centerline in the plane of the motor hub.

A positive sign indicates the dial indicator stem was compressed at the bottom. With the pump being fixed, the only way this can occur is if the motor shaft is low with respect to the pump shaft. Plot this point as shown in Fig. 14.

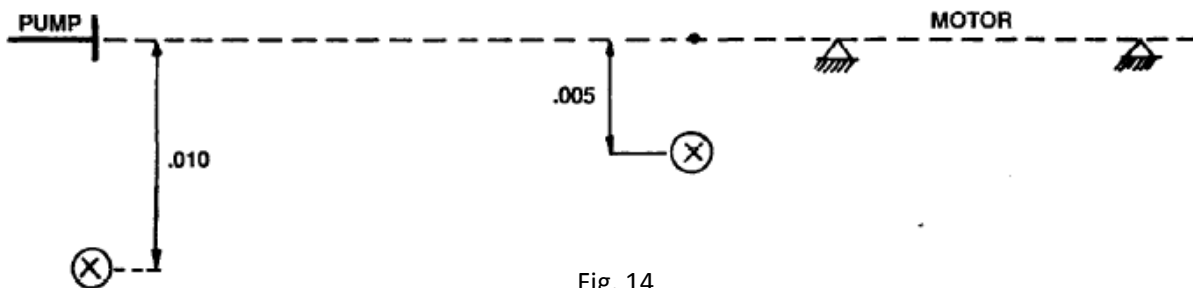

Fig. 14

Step 10: Determine vertical shimming required at front and back motor feet

With the pump shaft fixed, these two points represent the location of the motor shaft with respect to the pump shaft. Draw a line thru these two points extending past the plane of the front and back motor

feet as seen in Fig. 15. The vertical shim adjustments required to bring the two shafts into alignment can be read directly from the graph. In this example, .004 should be added to the front motor feet and .001 should be added to the back motor feet.

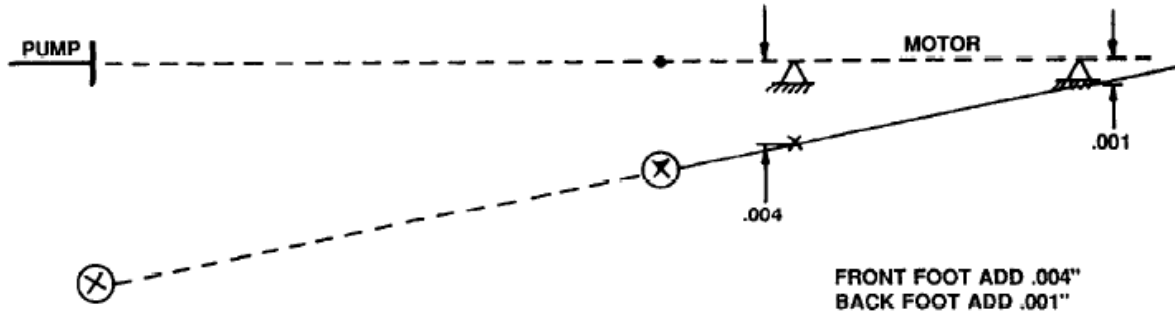

Fig. 15

Step 11: Horizontal (side to side) solution

Use the same procedure used for the vertical solution only you do not need to correct for sag as the side readings cancel. In the vertical solution you zeroed the top and read the bottom. For the horizontal, you can zero the “near” and read the “far” or vice versa. To zero a reading, simply subtract that reading from both side readings.

In our example, the side readings from the motor to the pump in Fig. 11 were negative -.005 (“near” or 9:00 o’clock) and negative -.015 (“far” or 3:00 o’clock). If you choose to zero the near and plot the far readings, subtract negative -.005 from both sides and your “near” reading is now zero and your “far” reading becomes -.010 $[-.015 - (-.005) = -.010.]$

C. Across the Flex Element Alignment

When the distance between coupling flex elements is long, making use of indicator brackets impractical or where lasers cannot be targeted due to obstructions or beam interference, Across the Flex Element Alignment method can be used.

In this method, angular and axial misalignment will be checked as described below respectively:

Angular alignment

Step 1: Squarely and firmly attach a dial indicator to the center member shaft and read across the flex element to the driver hub surface facing away from the indicator mounting as seen in Fig. 16.

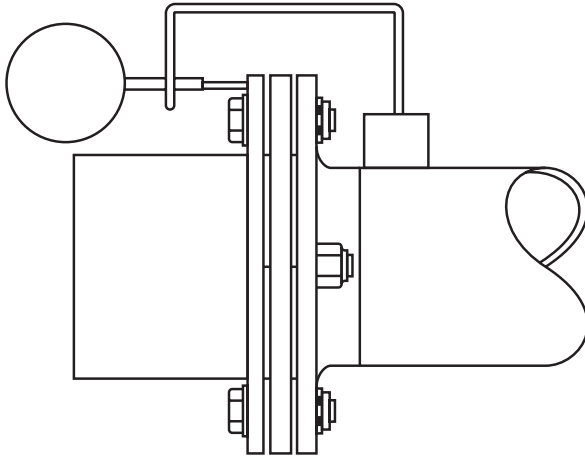

Fig. 16

Step 2: With the dial indicator set to zero, rotate the shaft one revolution and record the maximum and minimum dial indicator readings.

Step 3: If the range between the maximum and minimum reading is at or below .010 inch, the angular alignment is acceptable. If the range is greater than .010 inch, the equipment should be realigned.

Step 4: Repeat steps 1-4 on the driven side flex element.

Axial Alignment

To establish the axial misalignment, you will measure the gap between the spacer flange and connected equipment hubs, on both flex points of the coupling, and compare with published coupling limits.

Step 1: Without rotating the coupling, take four gap readings at 3:00, 6:00, 9:00 and 12:00 o'clock between the driver and center member flanges as seen in Fig. 17.

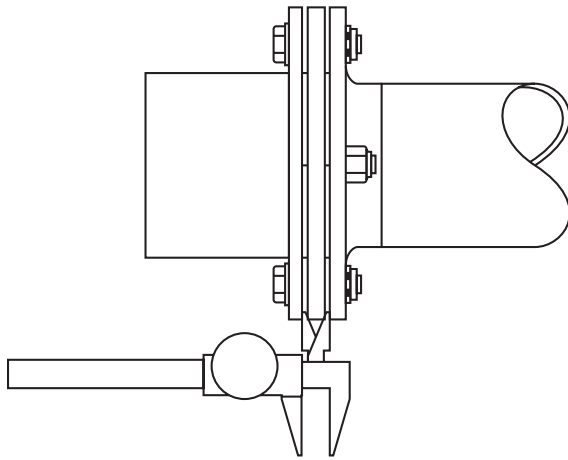

Fig. 17

Step 2: Average these four readings.

Step 3: Consult the coupling installation instructions for the coupling size and style being installed to be sure the average reading are within acceptable axial installation limits. If the coupling being aligned is an Addax® coupling, the nominal gap for all sizes is .540 inches and should be between .530 and .550 inches.

Step 4: Repeat steps 1-3 on the driven side flex element.